

---

**METROLOGIC INSTRUMENTS, INC.**

**MS700*i* Series Laser Bar  
Code Projection Scanner**

**Installation and User's Guide**

---

**MLPN 2178  
Printed in USA  
October 1998**

## **Locations:**

### **USA Corporate Headquarters**

Metrologic Instruments, Inc.  
90 Coles Road  
Blackwood, NJ 08012  
Customer Service: 1-800-ID-METRO  
Tel: 609-228-8100  
Fax: 609-228-6673  
info@metrologic.com  
www.metrologic.com

### **Europe**

Metrologic Instruments GmbH  
Dornierstrasse 2  
82178 Puchheim b.  
Munich, Germany  
Tel: 49-89-89018-0  
Fax: 49-89-89019-200  
metrologic@europe.metrologic.com

### **South America**

Metrologic Instruments  
Rua Flórida, 1.821-5º Andar-Brooklin  
CEP 04571-090, São Paulo-SP, Brasil  
Outside Brazil:  
Tel: 55-11-5505-6568  
Fax: 55-11-5505-1681  
info@sa.metrologic.com  
In Brazil:  
Tel: 55-11-5505-2396  
Fax: 55-11-5507-2301  
metrolog@br.metrologic.com

### **ASIA**

Metrologic Asia (PTE) Ltd.  
31, Kaki Bukit Road 3  
#05-08 Techlink  
Singapore 417818  
Tel: 65-842-7155  
Fax: 65-842-7166  
ant888@cyberway.com.sg

## **Copyright**

© 1998 by Metrologic® Instruments, Inc. All rights reserved. No part of this work may be reproduced, transmitted, or stored in any form or by any means without prior written consent, except by reviewer, who may quote brief passages in a review, or provided for in the Copyright Act of 1976.

Products and brand names mentioned in this document are trademarks of their respective companies.

# Table of Contents

---

Introduction .....	1
Unpacking List .....	2
Scanner Connections to the Host .....	3
Configuration of the Scanner to the Host System .....	4
Cloning Feature .....	5
Version 11 IBM 46XX Scanner .....	6
Configuring the Scanner .....	7
Configuring the IBM 46XX .....	8
IBM 4683 and 4693 Terminals Driven by a 46XX Store Controller Running 4680.OS or 4690.OS .....	8
IBM 4684 and 4694 Systems .....	8
Scanner Installation to a PC Keyboard Port .....	9, 10
PC Application Note .....	11
Installation of the MS700 Series Stand .....	12
Attaching the Scanner to the Stand .....	13
MS700 <i>i</i> and MS720 <i>i</i> Features .....	14
Visual Indicators .....	15-18
Volume Settings .....	19
Labels .....	20
InfraRed (IR) Object Sensor .....	21
Symbol Orientation .....	22
Active Scan Region for the MS700 <i>i</i> and MS715 <i>i</i> Scanner .....	23
Horizontal Scan Width vs. Distance for the MS700 <i>i</i> and MS715 <i>i</i> Scanner .	24

Active Scan Region for the MS720i Scanner .....	25
Horizontal Scan Width vs. Distance for the MS720i Scanner .....	26
Depth of Field for the MS700i and MS715i Scanner .....	27
Depth of Field and Symbol Specification for the MS700i and MS715i .	28, 29
Depth of Field for the MS720i Scanner .....	30
Depth of Field and Symbol Specification for the MS720i .....	31, 32
Maintenance .....	33
Applications and Protocols .....	33
<b>Appendix A</b>	
Specifications .....	34, 35
<b>Appendix B</b>	
Default Settings .....	36-41
<b>Appendix C</b>	
Pin Assignments .....	42-46
<b>Appendix D</b>	
Warranty and Disclaimer .....	47, 48
<b>Appendix E</b>	
Notices .....	49, 50
<b>Appendix F</b>	
Patents .....	51
Volume Control Card .....	52, 53
Index .....	53, 54

## Introduction

---

The MS700*i* Series Scanners are high throughput projection scanners that incorporate the latest in VLD (Visible Laser Diode) ASIC/VLSI and surface mount technologies. Each scanner consumes only 8 watts of power and can directly connect to many host systems that can support a scanning device. One thoughtful feature is a “sleep mode” that turns the laser and motor off when not in use. Other features include easy-to-see LED indicators that can be viewed from the top or front and a volume control card that can be scanned to control volume levels. There are two programming methods: through the ScanSelect™ programming guide or through ScanSet™ (an IBM PC compatible software program.)

With a scan speed of 2,000 lines per second, these scanners aggressively scan poorly printed bar codes and read torn and bent UPC, EAN and JAN bar codes immediately on the first pass at any roll angle. For close scanning, the MS700*i* and MS715*i*'s depth of field of 0.0mm - 178mm (0" - 7") is ideal. To accommodate applications where scanning items farther away from the scan window is preferred, the MS720*i*'s depth of field of 178mm - 381mm (7" - 15") is ideal.

## Unpacking List

---

The shipping carton should contain the following:

- ! Installation and User's Guide (MLPN: 2178)
- ! ScanSelect™ Scanner Programming Guide (MLPN: 2186)
- ! Volume Control Card (MLPN: 2346)
- ! MS700i /MS715i or MS720i Laser Bar Code Projection Scanner
- ! Power Supply (optional)
- ! Communication cable with connection for power supply (optional) or Communication Cable (optional)
- ! Stand #45483 (optional)

If any item is missing or to order additional items, contact the dealer, distributor or call Metrologic's Customer Service Department at 1-800-ID-METRO or 1-800-436-3876.

## Scanner Connections to the Host

---

To maintain compliance with applicable standards, all circuits connected to the scanner must meet the requirements for SELV (Safety Extra Low Voltage) according to EN 60950. To avoid potential problems, do not power up the scanner until the communication cable is secured to the host.

1. Turn off the host system.
2. Connect the 25-pin D-type connector on the scanner's head cable to the communication cable. Connect the other end of the communication cable to the host device. (If the scanner will not receive power from a transformer, skip to Step 5.)
3. If the scanner will receive power from an external power source, check the AC input requirements of the transformer to make sure the voltage matches the AC outlet. (A socket-outlet can be installed near the equipment so it will be easily accessible.)
4. Plug the transformer into the side of the female D-type connector located on the communication cable. Plug the transformer into the AC outlet to supply power to the scanner.
5. Power up the host system.

**Note:** When the scanner first receives power, the LEDs will flash and then the scanner will beep once. After the scanner performs this startup sequence, the green LED will remain on for a specified time indicating that the laser is on.

## **Configuration of the Scanner to the Host System**

The scanner is shipped from the factory programmed to a set of default conditions. These default conditions are in the *Default Settings* section of this guide pages 36-41 and in the ScanSelect™ Scanner Programming Guide. The default settings in the ScanSelect guide have an asterisk that appears before the brief definition next to the bar code.

For the scanner to properly communicate with the host system, it needs to be programmed to meet the specific scanning needs. Since each host system is unique, configure the scanner to match the host system requirements. Configure the scanner by entering program mode and scanning the appropriate bar codes that appear in the *ScanSelect Scanner Programming Guide*. (When using ScanSet™, refer to *the ScanSet* documentation for information on how to configure the scanner.)

1. Connect the scanner to the host system (Refer to the *Scanner Connections to the Host* section in this guide).
2. Enter program mode by scanning the ENTER/EXIT program mode bar code as the first bar code after a power up cycle. (The unit will beep three times)
3. Scan the appropriate bar code(s) that appear in the ScanSelect Scanner Programming Guide. (Reveal only one bar code to the scanner each time. With your hand, cover the bar code that is not to be scanned.)
4. Exit program mode by scanning the ENTER/EXIT program mode bar code again. (The new options will be saved and the scanner is ready for normal operation.)

**Note:** Non-RS-232 interfaces chosen in Section B of the ScanSelect Programming Guide do not match the default settings loaded when the same interface is selected with ScanSet.



## Cloning Feature

---

To program several scanners with the same settings, use the Cloning feature. This is done by connecting the cloning cable (MLPN: #51544) between two scanners.

1. Turn off both scanners.
2. Connect the cloning cable between the two scanners.
3. Turn both scanners on by plugging in the transformers.
4. Once each scanner is ready, scan the cloning bar code with the scanner that has the settings that need to be transferred to the other scanner.

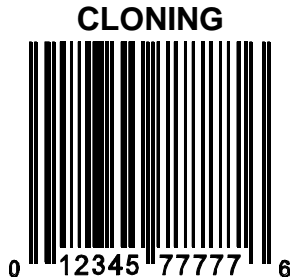

## Version 11 IBM 46XX Scanner

---

Output Format: IBM RS-485 serial input/output for the 4680 and 4690 (46XX) point-of-sale terminals

The Version 11 46XX interface can be used in several different ways. Both the 46XX terminal and the scanner must be configured to match each other.

**Warning:** Power to the scanner and 46XX terminal should be turned off before making physical connection.

The 4680 and 4690 series terminals have different types of physical ports for connecting bar code scanners. Scanner ports include Port 5B, Port 17, and Port 9? (? = A, B, C, or E). A Port 9 type connector is present on all versions of the 46XX families of terminals. That is one reason it is the normal point of connection for Metrologic scanners. Another reason is that there is enough 12 volt power available to operate many Metrologic scanners. If the terminal configuration requires use of a different physical port for connecting bar code scanners, contact Metrologic to get particular adaptor cable information.

No matter what port is in use for the physical connection, all devices use a common communications bus inside the 46XX terminal. Each device uses a different address when it must communicate. The terminal must be configured to look for a device at a logical address.

The IBM 1520 mode/address was selected as a default because it was the first IBM 46XX family scanner to support UPC/EAN, Code 39 and Interleaved 2 of 5. The Version 11 scanner formats Codabar, Code 128, and Code 93 using the Code 39 function code designation supported by the IBM device driver for this scanner type. Other emulation modes currently available are the IBM 3687-2 Port 17 fixed scanner and the Port 9B IBM 4500 CCD hand-held bar code reader. One of these other emulation modes may be needed depending on which operating system (4680.OS, 4690.OS, POS/DOS or DOS/RIPPS) is in use at the site.

**Note:** The IBM 4683 and IBM 4684 terminals have a good proven track record of supplying power to Metrologic scanners. The IBM 4693 and IBM 4694 terminals may be restricted from supplying power to certain scanner models. Specifically, Metrologic currently recommends using an external power supply for the scanner when connecting to an IBM 4694. Metrologic has no recommendations at this time for IBM 4693 terminals.

## Configuring the Scanner

---

Located in the Version 11 scanner are two computer boards. One board is for decoding and the other for 46XX IO processing. The decode board is configured using ScanSet™ or ScanSelect™ while the IO board is configured with an internal DIP Switch bank.

For UPC/EAN scanning, the decode board should be set as follows:

- Enable IBM 4680 Communication
- Enable UPC/EAN
- Beep after Transmit
- Enable Communication Timeouts
- Transmit UPC-A Check Digit
- Transmit UPC-E Check Digit

These settings configure the decode board to beep after transmitting the data to the terminal device driver. If the data does not clear the communications buffer within two seconds, it is discarded without giving the operator a good scan indication. This accommodates newer versions of the IBM device drivers that enable/disable scanning in many different situations.

The default setting of the interface board is to emulate the IBM 1520 hand scanner that supports UPC/EAN and alphanumeric code types. The following is a list of switch settings for the internal interface board that handles the 46XX SIOC communications.

There are eight DIP switches on the board that are both software and hardware switches.

Switch 1	Switch 2	Emulation Mode
OFF	OFF	Port 5B, IBM 1520 Model 2 Laser Scanner (default setting)
OFF	ON	Port 9B, CCD (IBM 4500/Opticon)
ON	OFF	Port 17, IBM 4014 Adaptor for 3687-2 to 468X
ON	ON	Reserved
Switch 3		Reserved (Should be OFF)
Switches 4, 5, 6, and 7		Must be ON
Switch 8		Should be OFF (Reserved)

## **Configuring the IBM 46XX**

---

The 4683 and 4693 terminals are configured on the store controller. The 4684 and 4694 terminals are typically configured on the individual terminals. Follow the appropriate guide for the type of equipment.

### **IBM 4683 and 4693 Terminals Driven by a 46XX Store Controller Running 4680.OS or 4690.OS**

Access the terminal configuration menu on the store controller. If not already selected, select an IBM 1520 laser hand scanner (4680.OS Port 5B), an IBM 4500 hand-held bar code reader (CCD, 4680.OS Port 9B), or an IBM 3687-2 fixed scanner (4680.OS Port 17) that matches the configuration of the scanner. Regarding the 4690.OS, at the time of this printing, Metrologic does not know exactly which terminal port configuration screen is used for selecting scanners. It should be listed under the Port 9A, 9B, 9C, or 9E sections. The 4693 terminal has a Port 5B that was originally used for the IBM 1520 scanner. While IBM has withdrawn this product, it was not clear how terminal configuration and device driver support would be provided for the installed base of users.

Save the configuration and activate it for the desired terminals. Download the configuration to the terminal(s) per standard procedures.

### **IBM 4684 and 4694 Systems**

Initialize the RIPPS drivers for a hand scanner if hand scanner emulation was selected. Initialize the RIPPS drivers for a "POS scanner" if the 3687-2 scanner has been selected.

## Scanner Installation to a PC Keyboard Port

---

The MS700i/MS715i/MS720i/ scanner (version 17) provides keyboard emulation by converting the scanned bar code data to the PC keyboard scan code equivalent. The following are the supported keyboard and country types:

### PC Type

- ! AT (includes IBM® PS/2 and compatible models 50, 55, 60, 80)
- ! XT
- ! PS/2 (includes IBM PC and compatible models 30, 70, 8556)

### Keyboard Country Type

- |           |                  |
|-----------|------------------|
| ! USA     | ! United Kingdom |
| ! France  | ! Germany        |
| ! Italy   | ! Spain          |
| ! Belgium | ! Swiss          |

The communication cable kit (MLPN: 45927) has a communication cable with one (1) 5 Pos female DIN connector and one (1) 6 Pos male mini DIN connector. The kit also includes an adaptor cable. This cable allows the scanner to plug into an IBM® PC XT or AT compatible computer or a PS/2 computer and keyboard.

With the appropriate communication cable, the scanner will also provide RS-232 or light pen emulation interface. When configuring the scanner for one interface versus another, change all necessary parameters for that particular interface. For instance, to configure the scanner for keyboard wedge emulation, recall defaults, select the PC type, keyboard country type and intercharacter delay. For further information, refer to the ScanSelect™ Scanner Programming Guide or ScanSet™ Scanner Configuration Guide.

To maintain compliance with applicable standards, all circuits connected to the scanner must meet the requirements for SELV (Safety Extra Low Voltage) according to EN 60950.

1. When connecting to a PS/2 computer, attach to the communication cable (#51573) the 5M 6F adaptor to the female connector and the 5F 6M adaptor to the male connector.

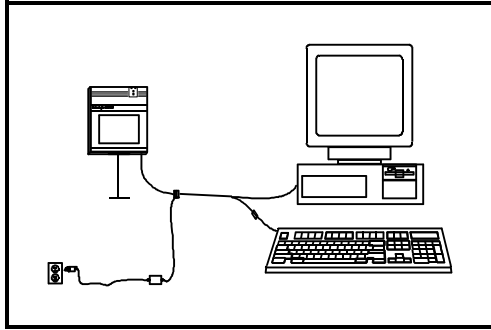

**Figure 1**

2. If the PC is on, exit the application and turn the PC off.
3. Disconnect the keyboard from the PC.
4. Plug the communication cable to the PC and the keyboard. (Refer to Figure 1).
5. Connect the 25-pin D-type connector on the scanner's head cable to the communication cable.
6. Check the AC input requirements of the transformer to make sure the voltage matches the AC outlet. (A socket-outlet shall be installed near the equipment and shall be easily accessible.)
7. Plug the transformer into the side of the female D-type connector located on the communication cable. Plug the transformer into the AC outlet to supply power to the scanner.
8. Turn the PC on.

**PC Application Note:**

For most applications, it will be desirable to disable linefeed transmission. For non-USA keyboards, 10 msec is probably the best intercharacter delay. Network system installations, may require tuning of the intercharacter and inter scan code options.

**Note:**

Once the scanner connects to the PC, the PC can be turned on and will operate normally even if the scanner's transformer plug is not in. However, bar codes will not be read until the scanner receives power. When the scanner first receives power, the LEDs will flash and then the scanner will beep once. After the scanner performs this startup sequence, the green LED will remain on for a specified time indicating the laser is on.

## Installation of the MS700 Series Stand

---

The following are components used to build the MS700 Series stand (MLPN: 45483):

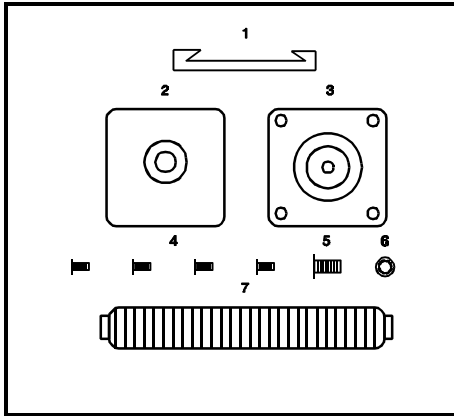

Figure 2

1	Shoe Mount	4	Four Wood Screws
2	Stand Cover	5	One Machine (1/4-20) Screw
3	Stand Base	6	Internal Lock Washer
		7	Flexible Shaft

1. Use the 2½ inch x 2½ inch stand base to mark the position for pilot holes.
2. Use the four wood screws to secure the base to the work surface.
3. Position the stand cover on top of the stand base.
4. Screw the flexible shaft to the stand base.
5. Place the internal lock washer on top of the flexible shaft and then screw the shoe to the shaft with the machine screw.



## Attaching the Scanner to the Stand

Once the stand is securely mounted to the work surface, attach the scanner.

The scanner has a “foot” that is at the bottom of the scanner. This foot fits into the “shoe” attached to the top of the stand. This construction helps prevent the scanner from being knocked from the stand.

1. To prevent obstruction when sliding the scanner into place, loosen the small screw (A) located in the center of the long part of the shoe with a 3/32" hex key wrench. (Refer to Figure 3)
2. Align the foot of the scanner with the shoe of the stand and slide the scanner into position.
3. Tighten the small screw (A) located at the center of the long part of the shoe. This screw holds the scanner in place.

**Note:** Fasten the stand to the work surface before adjusting the angle of the flexible shaft. To adjust the angle, firmly hold the shaft and push the shaft to a north, south, east, or west direction.

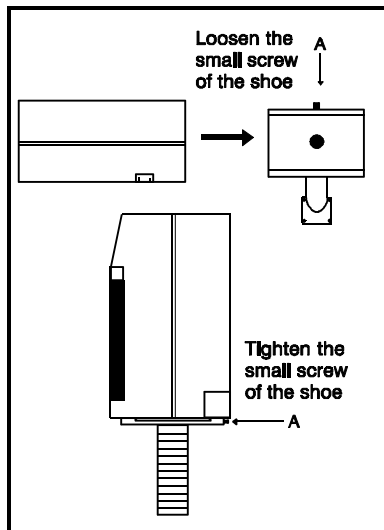

Figure 3

## MS700i and MS720i Series Features

---

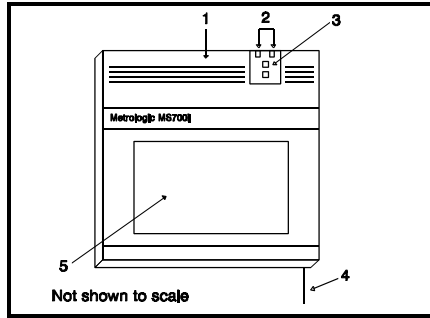

Figure 4

- |                                 |  |
|---------------------------------|--|
| <b>1 Speaker</b>                | The sound of a beep emits from here when the scanner performs a good read of a bar code.   |
| <b>2 Green and Red LEDs</b>     | When the green LED is on, this indicates that the unit is receiving power and the laser is on. When the red LED flashes on, the scanner has read a bar code successfully. When the red light turns off, communication to the host is complete. |
| <b>3 InfraRed Object Sensor</b> | When a specified time has elapsed without any scanning, the unit will enter a “standby” mode. The scanner will not return to scanning until an object or a wave your hand is passed in front of the IR sensor.                                 |
| <b>4 Head Cable</b>             | This cable can connect directly to the host device or to a communication cable.  |
| <b>5 Output Window</b>          | This aperture emits laser light.   |

# Visual Indicators

---

There is a red LED and a green LED located on the scanner. When the scanner is on, the flashing or stationary activity of the LEDs alert you to the status of the scan and scanner.

## **No Red or Green LED**

There are two reasons why the LEDs will not be illuminated. First, if the scanner is receiving power and the LEDs are not on, then the scanner has remained dormant for a specified period of time and the laser has turned off. To reactivate the unit, wave an object in front of the IR sensor. Secondly, if the scanner is not receiving power from the host or transformer, then the LEDs will not turn on.

## **Steady Green**

When the laser is on, the green LED is also on. This occurs when an object is in the scan field. The green LED will remain on until the IR time-out has elapsed or until the scanner is turned off.

## **Steady Green; Red Flash**

When the scanner successfully reads a bar code, the red LED will flash followed by one beep. If you do not see the red LED flash or the scanner beep once, then the bar code has not been successfully read.

## **Steady Red and Green**

After a successful scan, the scanner transmits the data to the host device. When the host is not ready to accept the information, the scanner's red LED will remain on until the data can be transmitted.

## **Alternating Red and Green**

This indicates the scanner is in program mode.

## **Steady Red**

This indicates the scanner is in ScanSet mode.

## **Flashing Red**

This indicates the scanner has experienced a laser subsystem failure. Return the unit for repair at an authorized service center.

## Signaux optiques

Sur la partie supérieure du scanner se trouvent une diode LED rouge et une diode LED verte. Quand le scanner est sous tension, les diodes rouge et verte clignotantes ou allumées vous informent sur l'état du scanner.

### **Ni la diode rouge, ni la diode verte n'est allumée**

Il existe deux raisons possibles pour que les diodes ne s'allument pas. Premièrement: si le scanner reçoit de l'énergie sans que les diodes ne s'allument, le scanner est resté sans servir pendant une certaine période et le laser est désactivé. Pour le réactiver, passer un objet devant le palpeur infrarouge. Deuxièmement: quand le scanner ne reçoit de l'énergie ni de l'ordinateur central, ni du transformateur, les diodes restent éteintes.

### **La diode verte reste allumée**

Quand le laser est en service, la diode verte s'allume également. C'est le cas quand un objet se trouve devant le palpeur. La diode verte reste allumée tant que la temporisation de l'infrarouge dure ou jusqu'à ce que le scanner soit désactivé.

### **La diode verte reste allumée; la diode rouge clignote**

Après lecture avec succès d'un code à barres par le scanner, la diode rouge se met à clignoter, suivie d'un bip sonore unique. Si la diode rouge ne clignote pas ou quand aucun bip sonore n'est émis, cela signifie que le code à barres n'a pas pu être lu avec succès.

### **Les diodes rouges et vertes restent allumées**

Une fois la lecture effectuée avec succès, le scanner transmet les données à l'ordinateur central. Si ce dernier n'est pas prêt à recevoir les données, la diode rouge du scanner reste allumée jusqu'à ce que les données puissent être transmises.

### **Les diodes rouges et vertes clignotent en alternance**

Indique que le scanner se trouve en mode de programmation.

### **La diode rouge reste allumée**

Indique que le scanner se trouve en mode ScanSet.

### **Diode rouge clignotante**

Indique une panne de laser pendant la lecture. Veuillez envoyer votre appareil chez un concessionnaire pour réparation.

## Optische Anzeigen

Auf dem Scanner befinden sich eine rote und eine grüne Leuchtdiode. Bei eingeschaltetem Scanner geben Ihnen die blinkenden bzw. feststehenden Leuchtdiodenanzeigen Aufschluß über den Abtast- und Scannerstatus.

### **Weder rote noch grüne Leuchtdiodenanzeige**

Es gibt zwei mögliche Gründe, weshalb die Leuchtdiodenanzeigen nicht aufleuchten. Erstens: Wenn der Scanner mit Energie versorgt wird und die Leuchtdiodenanzeigen nicht aufleuchten, so ist der Scanner für einen bestimmten Zeitraum untätig geblieben, und der Laser ist abgeschaltet. Zur Reaktivierung der Einheit sollten Sie ein Objekt vor dem Infrarot-Sensor hin- und herbewegen. Zweitens: Wenn der Scanner weder vom Hostrechner noch vom Transformator Energie erhält, so leuchten die Leuchtdiodenanzeigen nicht auf.

### **Feststehende grüne Anzeige**

Wenn der Laser in Betrieb ist, leuchtet die grüne Leuchtdiodenanzeige ebenfalls auf. Dies ist dann der Fall, wenn sich ein Objekt im Abtastfeld befindet. Die grüne Leuchtdiodenanzeige leuchtet solange auf, bis das Infrarot-Timeout abgelaufen ist, oder bis der Scanner abgeschaltet wird.

### **Feststehende grüne Leuchtanzeige; rote Blinkanzeige**

Nach erfolgreichem Lesen eines Barcodes durch den Scanner blinkt die rote Leuchtdiodenanzeige auf, gefolgt von einem einmaligen Piep-Signal. Blinkt die rote Leuchtdiodenanzeige nicht auf oder sendet der Scanner kein Piep-Signal aus, so konnte der Barcode nicht erfolgreich gelesen werden.

### **Feststehende rote und grüne Leuchtanzeige**

Nach erfolgreichem Abtasten überträgt der Scanner die Daten an das Hostgerät. Falls das Hostgerät zur Datenannahme nicht bereit ist, leuchtet die rote Leuchtdiodenanzeige des Scanners solange auf, bis die Daten übertragen werden können.

### **Alternierende rote und grüne Leuchtanzeige**

Zeigt an, daß sich der Scanner im Programmiermodus befindet.

### **Feststehende rote Leuchtanzeige**

Zeigt an, daß sich der Scanner im ScanSet-Modus befindet.

### **Aufblinkende rote Leuchtanzeige**

Zeigt an, daß beim Scanner ein Laserausfall vorliegt. Bringen Sie das Gerät zur Reparatur in ein Vertragsservicecenter.

## Segnali ottici

Sullo scanner si trovano due diodi luminosi: uno rosso e uno verde. Quando lo scanner è inserito, i diodi luminosi, che possono o essere accesi in continuazione o lampeggiare, Vi informano sullo stato della scansione e dell'apparecchio.

### **Né il diodo luminoso rosso né quello verde sono accesi**

Vi sono due possibili cause se i diodi luminosi non sono accesi. Prima causa: se lo scanner viene alimentato e i diodi luminosi non sono accesi, lo scanner è rimasto disattivato per un determinato periodo e il laser è spento. Per riattivare l'unità dovrete muovere un oggetto davanti al sensore a infrarossi. Seconda causa: se lo scanner non viene alimentato né dal calcolatore host né dal trasformatore, i due diodi luminosi non sono accesi.

### **Il diodo luminoso verde è acceso**

Quando il laser è inserito, è acceso anche il diodo luminoso verde. Questo si ha quando un oggetto si trova nella zona di scansione. Il diodo luminoso verde è acceso fino al raggiungimento del timeout infrarossi oppure fino allo spegnimento dello scanner.

### **Il diodo luminoso verde è acceso; quello rosso lampeggia**

Dopo la lettura riuscita di un codice a barre da parte dello scanner il diodo luminoso rosso lampeggia e quindi viene emesso un unico segnale beep. Se il diodo luminoso rosso non lampeggia oppure lo scanner non emette un segnale beep, ciò significa che la lettura del codice a barre non è riuscita.

### **Sono accesi sia il diodo luminoso rosso che quello verde**

Dopo la scansione riuscita lo scanner trasmette i dati all'host. Se l'host non è pronto per accettare i dati, il diodo luminoso rosso dello scanner è acceso fino a che i dati possono essere trasmessi.

### **Il diodo luminoso rosso e quello verde sono accesi in alternanza**

Ciò indica che lo scanner si trova nella modalità di programmazione.

### **Il diodo luminoso rosso è acceso**

Ciò indica che lo scanner si trova nella modalità ScanSet.

### **Il diodo luminoso rosso lampeggia**

Ciò indica che lo scanner ha un guasto a livello del laser. Fate riparare l'apparecchio da un centro di assistenza autorizzato.

## Volume Settings

---

There are four volume settings available: low, medium, high and no volume. The operator can temporarily change the volume of the scanner by scanning the bar codes on the volume control card. To permanently change the volume of the scanner, enter program mode and scan the appropriate volume setting bar code in Section C of the ScanSelect Programming Guide or use ScanSet.

**Note:** A copy of the volume control card is at the end of this guide.

# Labels

There is one label located inside the window of each scanner noting that the device is a CDRH Class IIa laser product and IEC 825 LASERKLASSE 1. Also on each scanner is a label located on the back of the unit. This label contains information such as the model number, date of manufacture, serial number, and approvals. The following are samples of these labels:

Complies with 21 CFR Chapter 1 subchapter J. Class IIa laser product. Avoid long-term viewing of direct laser light.

**LASERKLASSE 1**

**Metrologic**  
Metrologic Instruments, Inc.  
Blackwood, New Jersey, USA  
Contains no user serviceable components.  
Warranty void if case is opened.  
Complies with FCC Class A.  
See manual.

**SF** LR 69345  
**UL** Listed 91J0 I.T.E.  
**CE**  
**UL** C

This product complies with US DHS Standard 21 CFR Chapter 1 Subchapter J. Class IIa Laser Product. Avoid long-term viewing of direct laser light.  
Eviter toute exposition prolongée de la vue au rayonnement laser direct. Appareil laser Classe IIa

Manufactured Blackwood, NJ, February 1997 11-30V  
Model: MS700-J48  
Barcode Scanner  
Serial #: XXXXXXXXXXXX  
XXXXXXXXXXXX  
XXXXXXXXXXXX  
Patents #5,081,362; #5,218,232; #1,268,257  
Worldwide Patents Pending

**GS**  
gammastandard  
Blackwood, NJ

**CAUTION:**  
Laser light when opened.  
DO NOT STARE INTO BEAM.



## **InfraRed (IR) Object Sensor**

---

An infrared (IR) device located below the LEDs and above the scanner output window (refer to the section, *MS700i and MS720i Features* page 14) initiates the scanning process. As long as power is applied to the unit, the IR sensor projects a signal that extends approximately seven (7) inches beyond the output window. When the scanner's computer is on "standby," passing an object in front of this sensor device will "wake up" the scanner and activate the laser. The scanner will enter "standby" when it remains dormant for a time. When the green LED comes on, the scanner is powering up for full operation. After approximately three seconds, the scanner will be ready to operate.

The default IR timeout is ten minutes. However, this can be changed through ScanSet or by scanning a bar code in Section C of the ScanSelect Programming Guide. The available times are two minutes, thirty minutes or no timeouts.

## Symbol Orientation

---

To scan a symbol, it may be oriented in any of the degree angles shown in Figure 5. The roll, pitch, and yaw are  $360E$ ,  $\pm 60E$ , and  $\pm 60E$  respectively.

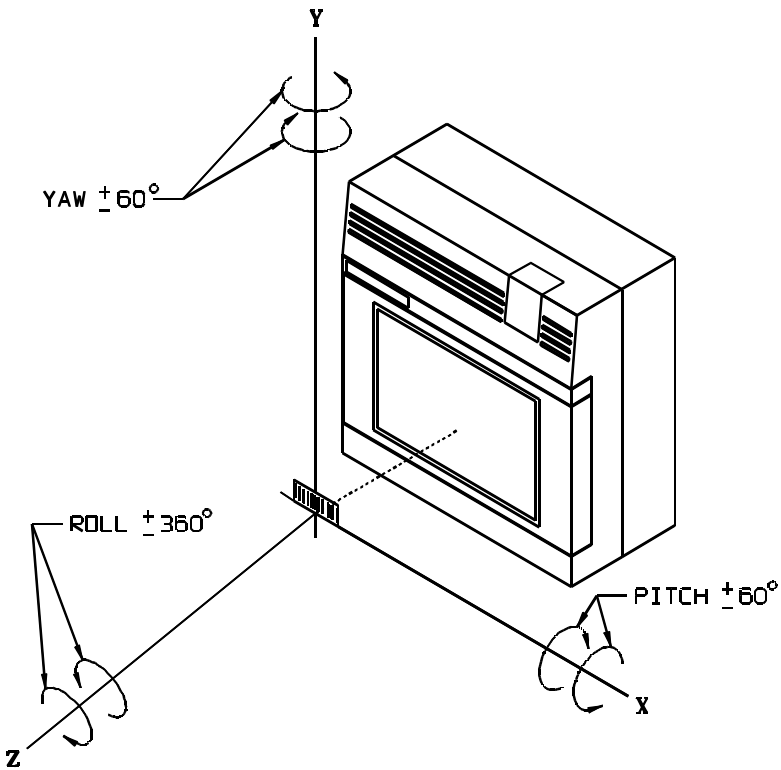

Figure 5

## Active Scan Region for the MS700i and MS715i Scanner

The active scan region is the region within the depth of field of the five scan segments in which the laser beam can intercept and read symbols oriented as shown in the section *Symbol Orientation* page 22. Planes formed by each of the five scan segments define the bottom of the region. The 178mm (7.0") depth of field of each of the scan segments bound the top. Best first pass read will be observed for symbols that pass through the optimal scan area along a 1½ inch wide track centered in the defined region shown in Figure 6. Optimal scan area range is 18mm - 160mm (.7" - 6.3").

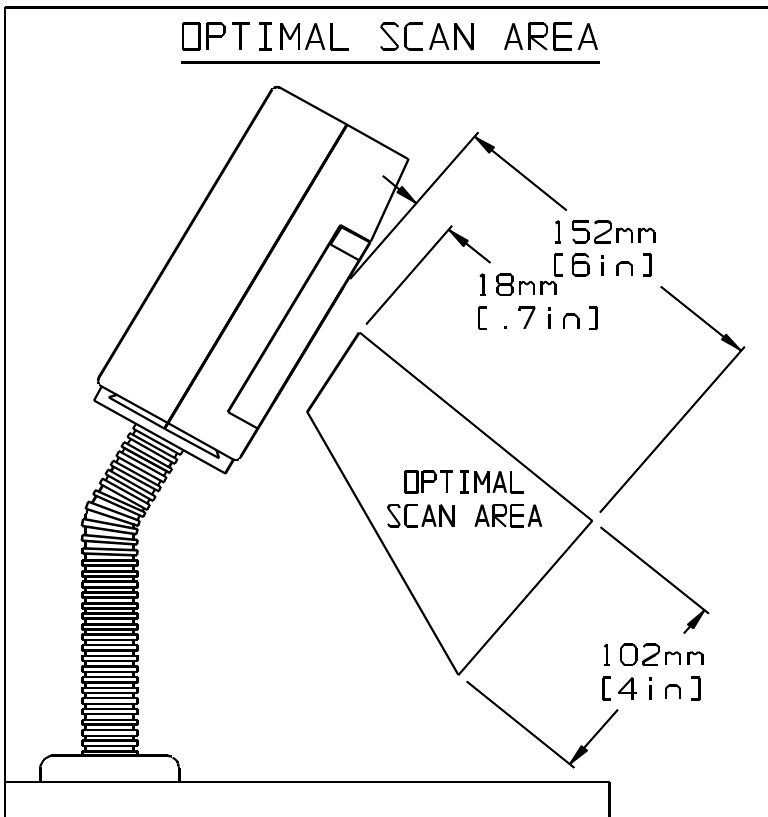

Figure 6

## Active Scan Region for the MS720i Scanner

The active scan region is the region within the depth of field of the five scan segments in which the laser beam can intercept and read symbols. The bottom of the region is 7" from the scanner window. Planes formed by each of the five scan segments define the sides. The 203mm (8.0") depth of field of each of the scan segments bound the top. Best first pass read will be observed for symbols that pass through the optimal scan area along a 2½ inch wide track centered in the defined region shown in Figure 7. Optimal scan area range is 203mm - 356mm (8" - 14").

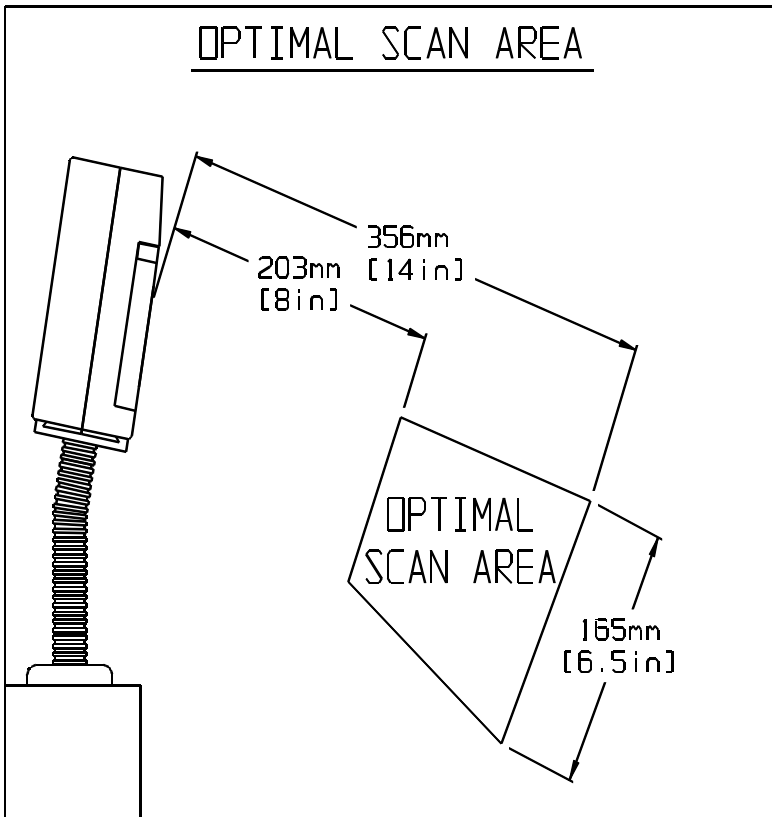

Figure 7

# Horizontal Scan Width vs. Distance for the MS700i and MS715i Scanner

The following illustration notes the measurements of the horizontal scan width at given distances.

TOP VIEW OF SCANNER

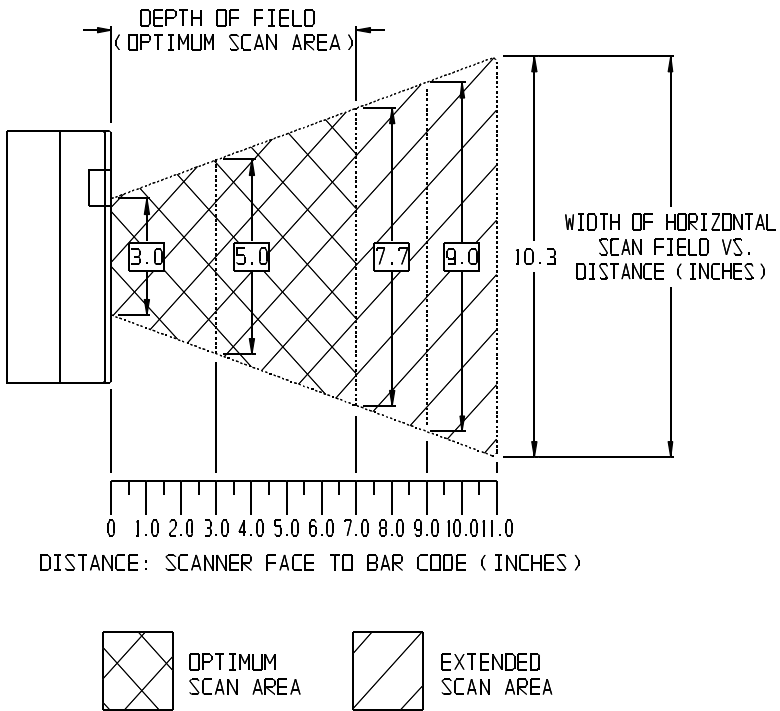

Figure 8

# Horizontal Scan Width vs. Distance for the MS720i Scanner

The following illustration notes the measurements of the horizontal scan width at given distances.

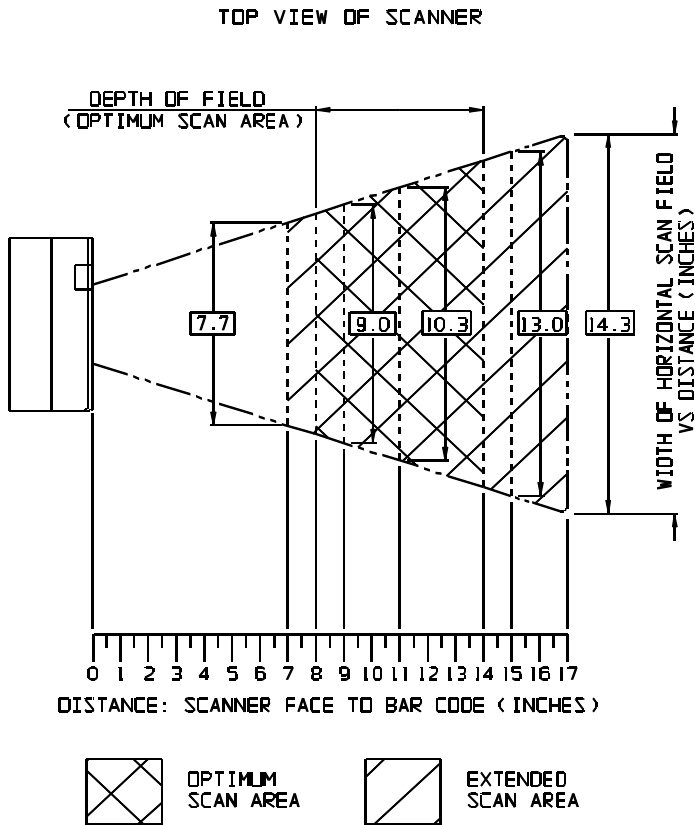

Figure 9

# Depth of Field for the MS700i and MS715i Scanner

Through the glass at the front of the scanner, safe, low powered laser beams are projected in a complex pattern that resembles a spider web. Each of the five scan fields that generate the scan pattern extends to a range of 178mm (7.0"). The range begins from the face of the scanner window and extends from the unit for a distance of 178mm (7.0") measured along the scanning beam at the center of each scan segment. This 0.0mm - 178mm (0" - 7") range is the depth of field for the MS700i and MS715i scanner (refer to Figure 10). This area of active scanning projects out from the glass on the face of the scanner to about 7 inches.

The scan pattern is projected at a slight angle downward from the front of the scanner (approximately 10 degrees, overall). As the scan fields move outward, they expand. Like an image expands from a film projector as it moves toward the screen at a movie theater, the scan pattern projects out to a well-defined region. Any label that is facing toward the scanner can be read at any point within the scanning field.

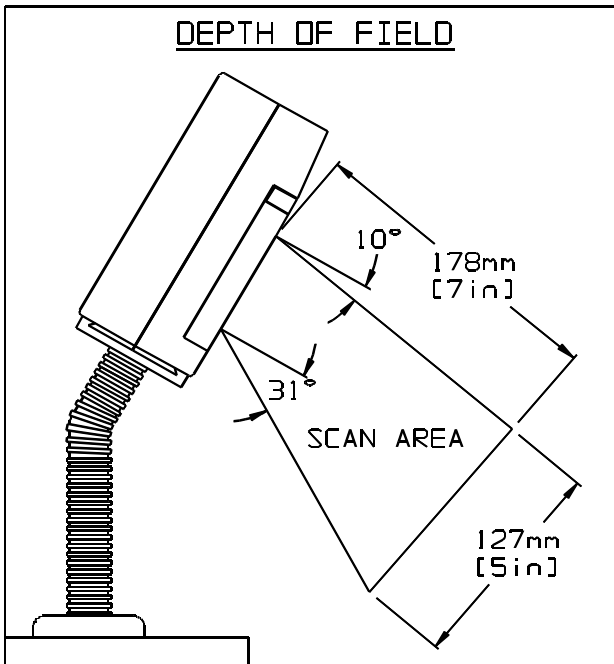

Figure 10

## **Depth of Field and Symbol Specification for the MS700i and MS715i (Refer to Figure 11)**

---

<b>Code Type</b>	<b>Minimum Small Element Mil. (1/1000")</b>	<b>Code Density</b>	<b>Depth of Field</b>
UPC/EAN	10.4	80%	0" - 5"
UPC/EAN	13.0	100%	0" - 7"
Code 39	7.5	High	0" - 4"
Code 39	12.0	Medium	1" - 7"
Code 39	21.0	Low	3" - 11"
I2 of 5	7.5	High	0" - 4"
I2 of 5	12.0	Medium	1" - 7"
I2 of 5	21.0	Low	3" - 11"
Codabar	7.5	High	0" - 4"
Codabar	12.0	Medium	1" - 7"
Codabar	21.0	Low	3" - 11"
Code 93	10.4	80%	0" - 4"
Code 93	13.0	100%	1" - 7"
Code 128	10.4	80%	0" - 4"
Code 128	13.0	100%	1" - 7"



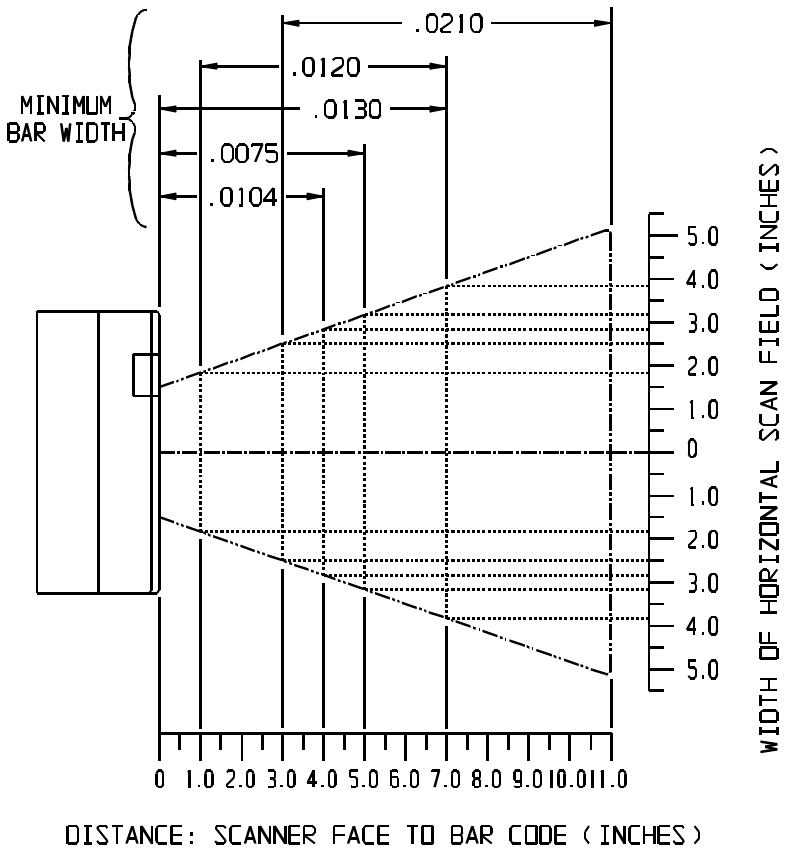

Figure 11

# Depth of Field for the MS720i Scanner

Through the glass at the front of the scanner, safe, low powered laser beams are projected in a complex pattern that resembles a spider web. Each of the five scan fields that generate the scan pattern extends to a range of 178mm (7.0"). The range begins 178mm (7.0") from the face of the scanner window and extends from the unit for a distance of 381mm (15.0") measured along the scanning beam at the center of each scan segment. This 178mm - 381mm (7" - 15") range is the depth of field for the MS720i scanner. (Refer to Figure 12)

The scan pattern is projected at a slight angle downward from the front of the scanner (approximately 10 degrees, overall). As the scan fields move outward, they expand. Like an image expands from a film projector as it moves toward the screen at a movie theater, the scan pattern projects out to a well-defined region. Any label that is facing toward the scanner can be read at any point within the scanning field.

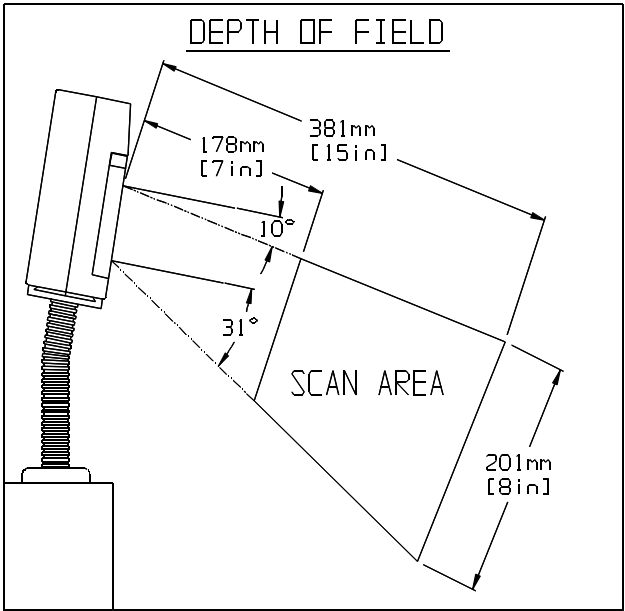

Figure 12

## Depth of Field and Symbol Specification for the MS720i (Refer to Figure 13)

---

Code Type	Minimum Small Element Mil. (1/1000")	Code Density	Depth of Field
UPC/EAN	10.4	80%	7" - 11"
UPC/EAN	13.0	100%	7" - 15"
Code 39	12.0	Medium	7" - 15"
Code 39	21.0	Low	9" - 17"
I 2 of 5	12.0	Medium	7" - 15"
I 2 of 5	21.0	Low	9" - 17"
Codabar	12.0	Medium	7" - 15"
Codabar	21.0	Low	9" - 17"
Code 93	10.4	80%	7" - 11"
Code 93	13.0	100%	7" - 15"
Code 128	10.4	80%	7" - 11"
Code 128	13.0	100%	7" - 15"

TOP VIEW OF SCANNER

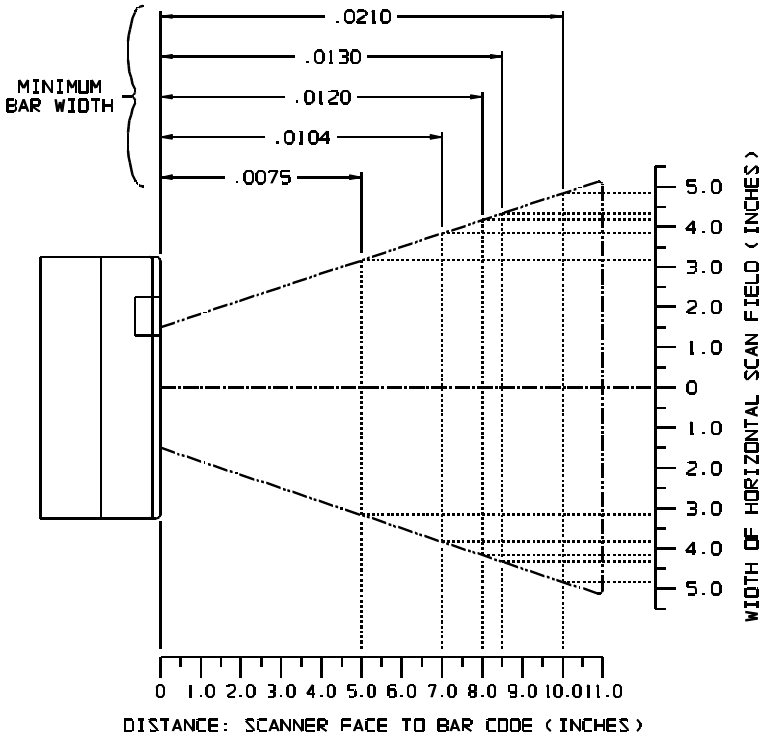

Figure 13

## Maintenance

---

Smudges and dirt can interfere with the proper scanning of a bar code. Therefore, the output window will need occasional cleaning.

1. Spray glass cleaner onto lint free, non-abrasive cleaning cloth.
2. Gently wipe the scanner window.

## Applications and Protocols

---

The model number on each scanner includes the scanner number and communications protocol.

<b>Scanner</b>	<b>Version Identifier</b>	<b>Communication Protocol(s)</b>
700i/715i/720i/	1 and 21	RS-232, OCIA, Light Pen Emulation
700i/715i/720i/	2	Parallel Output (OCR A/B)
700i/715i/720i/	26	RS-232, OCIA, Light Pen Emulation, Point to Point RS-422
700i/715i/720i/	17	Keyboard Wedge, RS-232, Light Pen
700i/715i/720i/	11 and 24	IBM 46XX - RS-485, RS-232, OCIA

The version “21” and “24” scanners are identical to the version “1” and “11” scanners, respectively, except for an EMI shell on the head cable.

# Appendix A

---

## Specifications

Application:	Laser Bar Code Projection Scanner
Light Source:	VLD 675 $\pm$ 5 nm, Maximum output 1mW
CDRH:	CLASS IIa laser product
EMC:	EN 60950: 1993, EN 60825:1:1994, laser class 1, EN 55022:1987 Class A, EN 55082-1:1992, IEC 801-2:1991 8kVAD, IEC 1004-3:1995 3V/m (except version 11), IEC 801-3:1984 3V/m (version 11), IEC 801-4:1988 1kV Power Lines
UL/CSA/TUV:	UL Listed, UL 114; CSA certified, C22.2 No. 950 TUV certified, GS Mark, EN 60825 and EN 60950
EMI:	Complies with FCC & VDE Class A

## Mechanical

Dimensions:	165mm x 165mm x 76mm (6.5"L x 6.5"W x 3.0"D)
Footprint on Stand:	64mm x 64mm (2.5" x 2.5")
Weight:	1.13kg (2.5 lbs.)
Orientation:	May be used in any orientation
Mounting:	Fully adjustable optional mount
Top Cover:	High impact ABS plastic; easily replaced window
Cable Length:	1.8mm (6') terminated with connector

## Electrical

Power Consumption:	8 watts, host system or tabletop power supply
Voltage:	Input: 11-30 VDC
Operating Current:	350mA @ 24 VDC
Standby Current:	175mA @ 24 VDC
DC Transformers:	6113 (220V AC in), 6114 (120V AC in) and 6115 (240V AC in) output 24 VDC @ 750mA

Specifications subject to change without notice.

Patent Numbers: 5,216,232; 5,081,342; 1,268,257; Other Patents Pending

## Operational

### Depth of Field:

MS700i, MS715i - 0.0mm - 178mm (0" - 7")  
MS720i - 178mm - 381mm (7" - 15")

### Scan Speed:

MS700i, MS720i 2000 scan lines per second  
MS715i 1000 scan lines per second

### Scan Pattern:

MS700i, MS720i 5 scan fields: 1 horizontal, 4 at angles  
MS715i 1 horizontal scan field, 10 line pattern

Projection Angle: 10E down off perpendicular of scan window

Indicators: LED: green=laser on; red=good read

Beeper Operation: 2 tones, 3 volume settings for "Good Read"

Maintenance Required: Clean window periodically

Decode Capability: Auto-discriminates

System Interfaces: RS-232C/OCIA, Parallel, IBM® 468X/469X,  
Light Pen Emulation, Point to Point RS-422,  
PC Keyboard Wedge

Print Contrast: 35% minimum reflectance difference

### Roll, Pitch, Yaw:

MS700i, MS720i 360E, 60E, 60E  
MS715i 42E, 60E, 52E

## Environmental

Storage Temperature: -40EC to 60EC (-40EF to 140EF)

Operating Temperature: 0EC to 35EC (32EF to 95EF)

Humidity: 5% to 95% relative humidity, non-condensing

Light Levels: Up to 3200 foot candles; works in direct  
sunlight

Ventilation: None required

Shock: 100g for 1ms

ESD: 15 kV IEC 801-2 Level 4

Contaminants: Sealed to resist airborne particulate  
contaminants

Specifications subject to change without notice.

## Appendix B

### Default Settings

Many functions of the scanner can be "programmed" - that is, enabled or disabled. The scanner is shipped from the factory programmed to a set of default conditions. The default parameter of the scanner has an asterisk ( \* ) in the charts on the following pages. If an asterisk is not in the default column then the default setting is Off or Disabled. Every communication does not support every parameter. If the communication supports a parameter listed in the charts on the following pages, a check mark will appear.

Parameter	Default	OCIA	IBM 46XX	RS- 232*	Parallel	Light Pen
UPC/EAN	*	T	T	T	T	T
Code 128	*	T	T	T		T
Code 93	*	T	T	T		T
Codabar	*	T	T	T		T
Interleaved 2 of 5 (ITF)	*	T	T	T		T
MOD 10 Check on ITF		T	T	T		T
Code 11		T	T	T		T
Code 39	*	T	T	T		T
Full ASCII Code 39		T	T	T		T
MOD 43 Check on Code 39		T	T	T		T
MSI-Plessey		T	T	T		T
MSI-Plessey 10/10 Check Digit		T	T	T		T
MSI-Plessey MOD 10 Check Digit	*	T	T	T		T
MECCA		T	T	T	T	T
Paraf Support		T	T	T		T
ITF Symbol Lengths	Variable	T	T	T	T	T



Parameter	Default	OCIA	IBM 46XX	RS- 232*	Parallel	Light Pen
Minimum Symbol Length	04	T	T	T	T	T
Symbol Length Lock	None	T	T	T	T	T
SWEDA					T	
Fujitsu					T	
OMRON	*				T	
IBM Parallel					T	
Bars High as Code 39	*					T
Spaces High as Code 39						T
Bars High as Scanned						T
Spaces High as Scanned						T
DTS/SIEMENS		T				
DTS/NIXDORF		T				
NCR F		T				
NCR S		T				
Poll Light Pen Source						T
Beeper Tone	Normal	T	T	T	T	T
Volume Setting	Loudest	T	T	T	T	T
Beep/Transmit Sequence	Before Transmit	T	T	T	T	T
Communication Timeout	None	T	T	T	T	T
Communication Timeout	None	T	T	T	T	T
Razzberry Tone on Timeout		T	T	T	T	T

Parameter	Default	O CIA	IBM 46XX	RS- 232*	Parallel	Light Pen
Three Beeps on Timeout		T	T	T	T	T
No Beeps on Timeout		T	T	T	T	T
IR Timeout	10 Min.	T	T	T	T	T
Same Symbol Rescan Timeout: 200 msecs		T	T	T	T	T
Same Symbol Rescan Timeout: 500 msecs	*	T	T	T	T	T
Same Symbol Rescan Timeout: 1250 msecs		T	T	T	T	T
Same Symbol Rescan Timeout: 2000 msecs		T	T	T	T	T
Scanability	Off			T		
Intercharacter Delay	1 msecs	T		T	T	
Scan Buffer	1	T	T	T	T	T
Transmit UPC- A Check Digit	*	T	T	T	T	
Transmit UPC-E Check Digit		T	T	T	T	
Expand UPC-E		T	T	T	T	
Convert UPC-A to EAN-13		T	T	T	T	
Transmit Lead Zero on UPC-E		T	T	T	T	
Convert EAN-8 to EAN-13		T	T	T	T	

Parameter	Default	OCIA	IBM 46XX	RS- 232*	Parallel	Light Pen
Transmit UPC- A Number System	*	T	T	T	T	
Transmit Codabar Start/Stop Characters		T	T	T	T	
CLSI Editing (Enable)		T	T	T		
Transmit Mod 43 Check Digit on Code 39		T	T	T		
Transmit Code 39 Stop/Start Characters		T	T	T		
Transmit Mod 10/ITF		T	T	T		
Transmit Code 11 Check Digit		T	T	T		T
Transmit MSI- Plessey Check Characters		T	T	T		
Parity	Space			T		
Baud Rate	9600			T		
8 Data Bits				T		
7 Data Bits	*			T		
Transmit Sanyo ID Characters				T		
Nixdorf ID				T		
Shell Schulmberger Formatting				T		
UPC Prefix				T		
UPC Suffix				T		
Transmit AIM ID Characters				T		

Parameter	Default	OCIA	IBM 46XX	RS- 232*	Parallel	Light Pen
STX Prefix				T		
ETX Suffix				T		
Carriage Return	*			T		
Line Feed	*			T		
Tab Prefix				T		
Tab Suffix				T		
"DE" Disable Command				T		
"FL" Laser Enable Command				T		
DTR Handshaking Support				T		
RTS/CTS Handshaking				T		
Character RTS/CTS	*			T		
Message RTS/CTS				T		
XON/XOFF Handshaking				T		
ACK/NAK				T		

Parameter	Default	OCIA	IBM 46XX	RS- 232*	Parallel	Light Pen
Special Software is required for the following:						
Two Digit Supplements		T	T	T		T
Five Digit Supplements		T	T	T		T
Bookland		T	T	T		T
977 (2 digit) Supplemental Requirement		T	T	T		T
Supplements are not Required	*	T	T	T		T
Two Digit Redundancy	*	T	T	T		T
Five Digit Redundancy		T	T	T		T
200 msec to Find Supplement		T	T	T		T
100 msec to Find Supplement	*	T	T	T		T

# Appendix C

---

## Pin Assignments

### Versions “1” and “21” Pin Assignments for RS-232, OCIA and Light Pen Emulation

The version “1” and “21” scanners head cables are terminated with a male 25-pin D-type connector. To connect the scanner to the host device, may require a communication cable. The communication cable may include a connection for a transformer or it may be designed to draw power directly from the host device. This item can be ordered at the same time scanner is purchased.

The version “1” and “21” scanners are designed to be used for RS-232, OCIA or Light Pen Emulation communication.

The following is a list of the pin assignments. The pin numbers are impressed on the head cable’s connector.

<b>Pin</b>	<b>Function</b>
1	AC Shield Ground
2	RS-232 Receive Input
3	RS-232 Transmit Output
4	CTS Input
5	RTS Output
6	Reserved
7	Signal Ground
8 - 12	Reserved
13	Earth Ground
14	Power Ground 1
15	Light Pen Source
16	Light Pen Data
17	OCIA Clock In Return
18	OCIA Clock In
19	Power (11 - 30 volts) DC
20	DTR Input
21	OCIA Clock Out
22	OCIA Clock Out Return
23	OCIA RDATA
24	OCIA RDATA Return
25	Power Ground 2

## Version “2” Pin Assignments for Parallel Communication

The version “2” scanner head cable is terminated with a male 25-pin D-type connector. To connect the scanner to the host device, may require a communication cable. The communication cable may include a connection for a transformer or it may be designed to draw power directly from the host device. This item can be ordered at the same time scanner is purchased.

The version “2” scanner is designed to be used for Parallel communication.

The following is a list of the pin assignments. The pin numbers are impressed on the head cable’s connector.

<b>Pin</b>	<b>Function</b>
1	AC Shield Ground
2	RS-232 Receive Input
3	RS-232 Transmit Output
4	CTS Input
5	RTS Output
6	Reserved
7	Signal Ground
8	Reserved
9	Edit Check
10	EOT
11	Data Ready
12	Adaptor Ready
13	Earth Ground
14	Power Ground 1
15	Light Pen Source
16	Light Pen Data
17	Data 1
18	Data 2
19	Power (11 - 30 volts) DC
20	DTR Input
21	Data 3
22	Data 4
23	Data 5
24	Data 6
25	Power Ground 2

## Version “26” Pin Assignments for Multi-drop RS-422

The version “26” scanner head cable is terminated with a male 25-pin D-type connector. To connect the scanner to the host device, may require a communication cable. The communication cable may include a connection for a transformer or it may be designed to draw power directly from the host device. This item can be ordered at the same time scanner is purchased.

The version “26” scanner is designed to be used for Point to Point RS-422 communication.

The following is a list of the pin assignments. The pin numbers are impressed on the head cable’s connector.

<b>Pin</b>	<b>Function</b>
1	AC Shield Ground
2	RS-232 Receive Input
3	RS-232 Transmit Output
4	CTS Input
5	RTS Output
6	Reserved
7	Signal Ground
8	Reserved
9	Master Data +
10	Master Data -
11	Slave Data +
12	Slave Data -
13	Earth Ground
14	Power Ground 1
15	Light Pen Source
16	Light Pen Data
17	OCIA Clock In Return
18	OCIA Clock In
19	Power (11 - 30 volts) DC
20	DTR Input
21	OCIA Clock Out
22	OCIA Clock Out Return
23	OCIA RDATA
24	OCIA RDATA Return
25	Power Ground 2



## Versions “11” and “24” Pin Assignments for RS-485

The version “11” and “24” scanners head cables are terminated with a male 25-pin D-type connector. To connect the scanner to the host device, may require a communication cable. The communication cable may include a connection for a transformer or it may be designed to draw power directly from the host device. This item can be ordered at the same time scanner is purchased.

The version “11” and “24” scanners are designed to be used primarily with IBM® 46XX series of electronic cash registers. It can also be configured to communicate using the full RS-232 and OCIA protocol.

The following is a list of the pin assignments. The pin numbers are impressed on the head cable’s connector.

<b>Pin</b>	<b>Function</b>
1	AC Shield Ground
2	RS-232 Receive Input
3	RS-232 Transmit Output
4	CTS Input
5	RTS Output
6	Reserved
7	Signal Ground
8 - 12	Reserved
13	Earth Ground
14	Power Ground 1
15	468X -B
16	468X +A
17	OCIA Clock In Return
18	OCIA Clock In
19	Power (11 - 30 volts) DC
20	DTR Input
21	OCIA Clock Out
22	OCIA Clock Out Return
23	OCIA RDATA
24	OCIA RDATA Return
25	Power Ground 2

## Version “17” Pin Assignments for Keyboard Wedge, RS-232 and Light Pen Emulation

The version “17” scanner head cable is terminated with a male 25-pin D-type connector. To connect the scanner to the PC, may require a communication cable and a transformer. The communication cable is terminated to two 5-pin DIN connectors that will directly connect to an IBM PC XT or AT compatible computer and keyboard. For the scanner to connect to an IBM PS/2 computer and keyboard, an adaptor kit with 6-pin mini-DIN connectors is provided when requested.

The version “17” scanner is designed to be used as a keyboard wedge. However, with the appropriate communication cable, the scanner will also provide RS-232 or light pen emulation interface. When configuring the scanner for one interface versus another, change all necessary parameters for that particular interface. For instance, to configure the scanner for keyboard wedge emulation, recall defaults, select the PC type, keyboard country type and intercharacter delay. For further information, refer to the ScanSelect™ Scanner Programming Guide or ScanSet™ Scanner Configuration Guide.

The following is a list of the pin assignments. The pin numbers are impressed on the head cable’s connector.

<b>Pin</b>	<b>Function</b>	<b>Pin</b>	<b>Function</b>
1	AC Shield Ground	14	Power Ground 1
2	RS-232 Receive Input	15	Light Pen Source
3	RS-232 Transmit Output	16	Light Pen Data
4	CTS Input	17	PC Data
5	RTS Output	18	PC Clock
6	Reserved	19	Power (11 - 30 volts) DC
7	Signal Ground	20	DTR Input
8 - 10	Reserved	21	Keyboard Clock
11	PC +5 Volts DC	22	Keyboard Data
12	Ground	23 - 24	Reserved
13	Earth Ground	25	Power Ground 2

## Appendix D

---

### Warranty and Disclaimer

#### Limited Warranty

Products manufactured by Metrologic have a 2-year limited warranty from date of manufacture.

This warranty is limited to repair, replacement or refund at Metrologic's discretion. Faulty equipment must be returned to the Metrologic facility in Blackwood, New Jersey or Puchheim, Germany. To do this, contact Metrologic Customer Service/Repair for a Returned Material Authorization (RMA) number.

In the event that it is determined that the equipment failure is covered under the warranty, Metrologic shall, as its sole option, repair, replace with a functionally equivalent unit, or refund an amount equal to the purchase price to the original purchaser, whether distributor, dealer/reseller, or retail consumer, and return the equipment to the customer without charge for service or return freight.

This limited warranty does not extend to any Product which, in the sole judgment of Metrologic, has been subjected to misuse, neglect, improper installation or accident, nor does it extend to any Product which has been repaired or altered by anyone who is not a Metrologic authorized representative.

THIS LIMITED WARRANTY, EXCEPT AS TO TITLE, IS IN LIEU OF ALL OTHER WARRANTIES, EXPRESS OR IMPLIED, INCLUDING MERCHANTABILITY OR FITNESS FOR ANY PARTICULAR PURPOSE, ARISING BY LAW, CUSTOM OR CONDUCT. THE RIGHTS AND REMEDIES PROVIDED HEREIN ARE EXCLUSIVE AND IN LIEU OF ANY OTHER RIGHTS OR REMEDIES. IN NO EVENT SHALL METROLOGIC BE LIABLE FOR INDIRECT, INCIDENTAL, OR CONSEQUENTIAL DAMAGES, INCLUDING, WITHOUT LIMITATION, ANY INJURY TO PROPERTY OR PERSON OR EFFECT ON BUSINESS OR PROFIT, AND IN NO EVENT SHALL ANY LIABILITY OF METROLOGIC EXCEED THE ACTUAL AMOUNT PAID TO METROLOGIC FOR THE PRODUCT.

**Metrologic Instruments, Inc.**  
90 Coles Road  
Blackwood, NJ 08012

**Customer Service Department**  
1-800-ID-METRO (1-800-436-3876)  
TEL: 609-228-8100  
FAX: 609-228-6673

**Metrologic Instruments GmbH**  
Dornierstrasse 2  
82178 Puchheim b.  
Munich, Germany  
TEL: 49-89-89019-0  
FAX: 49-89-89019-200

## **Disclaimer**

Metrologic Instruments, Inc. and the author or authors make no claims or warranties with respect to the contents or accuracy of this publication, or the product it describes, including any warranties of fitness or merchantability for a particular purpose. Any stated or expressed warranties are in lieu of all obligations or liability for any damages, whether special, indirect, or consequential, arising out of or in connection with the use of this publication or the product it describes. Furthermore, the right is reserved to make any changes to this publication without obligation to notify any person of such changes. Metrologic also reserves the right to make any changes to the product described herein.

## **Exclusion des responsabilités**

Metrologic Instruments, Inc. et le/les auteur(s) ne sont ni garants, ni responsables pour l'exhaustivité et la correction des informations contenues dans cette brochure - que ce soit relativement à leur teneur et à l'exactitude - ou pour le produit qui y est décrit. Ils ne sont en outre responsables d'aucune garantie de propriété ou de qualité pour un usage particulier. Toutes les assurances nommées ou exprimées excluent toute garantie ou responsabilité pour les dommages spéciaux, indirects ou des suites de l'utilisation de cette brochure ou du produit qui y est décrit respectivement. en rapport avec l'emploi de cette brochure et du produit qui y est décrit. Il leur est également réservé le droit de procéder à des modifications de cette brochure sans avoir à en avertir qui que ce soit. Metrologic se réserve en outre le droit de procéder à des modifications du produit qui y est décrit.

## **Haftungsausschluß**

Metrologic Instruments, Inc. und der/die Autor(en) übernehmen keinerlei Gewähr und haften nicht für die Richtigkeit im Hinblick auf Inhalt oder Genauigkeit der Angaben dieser Veröffentlichung oder des hierin beschriebenen Produkts. Sie übernehmen ebenso keinerlei Eignungsgarantie oder Gewährleistung durchschnittlicher Qualität für einen bestimmten Zweck. Alle benannten oder ausdrücklichen Zusicherungen schließen sämtliche Verpflichtungen oder Haftungen aus jeglichem Schaden aus, ganz gleich ob speziell, indirekt oder als Folge der Verwendung dieser Veröffentlichung oder des hierin beschriebenen Produkts bzw. in Zusammenhang mit der Verwendung dieser Veröffentlichung oder des hierin beschriebenen Produkts. Darüber hinaus wird das Recht vorbehalten, Änderungen an dieser Veröffentlichung vorzunehmen ohne die Verpflichtung, irgend jemanden über solche Änderungen zu unterrichten. Metrologic behält sich ferner das Recht vor, Änderungen an dem hierin beschriebenen Produkt vorzunehmen.

## **Esclusione della responsabilità**

La Metrologic Instruments, Inc. e l'autore/gli autori non assumono nessuna garanzia e non rispondono della correttezza per quanto riguarda il contenuto o la precisione di quanto indicato nel presente Manuale o del prodotto in esso descritto. Neppure essi assumono una garanzia per l'idoneità o una garanzia della qualità media per un determinato scopo. Tutte le garanzie citate o fatte espressamente escludono qualsiasi obbligo o responsabilità derivanti da qualsiasi danno, indipendentemente dal fatto che questo obbligo/questa responsabilità risulti in particolare, indirettamente o come conseguenza dall'uso del presente Manuale o del prodotto in esso descritto oppure se è legato/a all'uso del presente Manuale o del prodotto in esso descritto. Inoltre ci si riserva il diritto di modificare il presente Manuale senza essere obbligati ad informare persona alcuna circa dette modifiche. Metrologic si riserva il diritto di apportare modifiche al prodotto descritto nel presente Manuale.

# Appendix E

---

## Notices

### Notice

This equipment has been tested and found to comply with limits for a Class A digital device, pursuant to Part 15 of the FCC Rules. These limits are designed to provide reasonable protection against harmful interference when the equipment is operated in a commercial environment. This equipment generates, uses and can radiate radio frequency energy and, if not installed and used in accordance with the instruction manual, may cause harmful interference to radio communications. Operation of this equipment in a residential area is likely to cause harmful interference, in which case the user will be required to correct the interference at his own expense. Any unauthorized changes or modifications to this equipment could void the users authority to operate this device.

### Notice

This digital apparatus does not exceed the Class A limits for radio noise emissions from digital apparatus set out in the Radio Interference Regulations of the Industry and Canada.

### Caution

Use of controls or adjustments or performance of procedures other than those specified herein may result in hazardous laser light. Under no circumstances should the customer attempt to service the laser scanner. Never attempt to look at the laser beam, even if the scanner appears to be nonfunctional. Never open the scanner in an attempt to look into the device. Doing so could result in hazardous laser light exposure. The use of optical instruments with the laser equipment will increase eye hazard.

### Remarque

Après contrôle de cet appareil, on a noté qu'il répondait aux valeurs limites de la classe A, conformément à la partie 15 des directives de l'administration fédérale américaine pour les télécommunications. Ces valeurs limites ont été prévues pour garantir une protection suffisante contre les effets nocifs dus à l'emploi de l'appareil dans un magasin. L'appareil génère et utilise une énergie haute fréquence et peut, s'il n'est pas installé et utilisé conformément aux instructions mentionnées dans le guide d'utilisation, entraîner des perturbations dans la radiocommunications. L'utilisation de cet appareil dans une zone d'habitation entraînera très vraisemblablement des perturbations. Dans ce cas, l'utilisateur est tenu de remédier à ces perturbations à ses propres frais. Toute modification ou remplacement non autorisé sur cet appareil peut entraîner l'invalidité de l'autorisation d'utilisation de l'appareil.

### Remarque

Cet appareil numérique ne va pas contre les valeurs limites pour émissions de bruits radios des appareils numérique de la classe A, conformément aux directives relatives aux perturbations des radiocommunications du ministère canadien pour l'industrie.

### Attention

L'emploi de commandes, réglages ou procédés autres que ceux décrits ici peut entraîner de graves irradiations. Le client ne doit en aucun cas essayer d'entretenir lui-même le scanner ou le laser. Ne regardez jamais directement le rayon laser, même si vous croyez que le scanner est inactif. N'ouvrez jamais le scanner pour regarder dans l'appareil. Ce faisant, vous vous exposez à une rayonnement laser mortel. L'emploi d'appareils optiques avec cet équipement laser augmente le risque d'endommagement de la vision.

### **Anmerkung**

Nach Überprüfung dieses Geräts wurde festgestellt, daß es den Grenzwerten für Digitalgeräte der Klasse A gemäß Teil 15 der Richtlinien der US-amerikanischen Bundesbehörde für das Fernmeldewesen entspricht. Diese Grenzwerte wurden festgelegt, um einen angemessenen Schutz gegen schädliche Auswirkungen bei Einsatz des Geräts in einer Ladenumgebung zu gewähren. Das Gerät erzeugt und verwendet Hochfrequenzenergie und kann diese ausstrahlen, und kann, falls es nicht gemäß den im Bedienerhandbuch enthaltenen Anweisungen installiert und verwendet wird, zu einer Störung des Funkverkehrs führen. Der Betrieb dieses Geräts in einem Wohngebiet führt höchstwahrscheinlich zu Störungen. In diesem Fall ist der Bediener verpflichtet, die Störung auf eigene Kosten zu beseitigen. Durch jegliche unerlaubte Auswechslung oder Änderung an diesem Gerät könnte die Genehmigung des Bedieners zur Verwendung dieses Geräts ungültig werden.

### **Anmerkung**

Dieses Digitalgerät verstößt nicht gegen die Grenzwerte für Funkrauschemissionen von Digitalgeräten der Klasse A gemäß den Richtlinien für Funkstörungen des kanadischen Ministeriums für Industrie.

### **Achtung**

Die Verwendung anderer als der hierin beschriebenen Steuerungen, Einstellungen oder Verfahren kann eine lebensgefährliche Laserstrahlung hervorrufen. Der Kunde sollte unter keinen Umständen versuchen, den Laser-Scanner selbst zu warten. Sehen Sie niemals in den Laserstrahl, selbst wenn Sie glauben, daß der Scanner nicht aktiv ist. Öffnen Sie niemals den Scanner, um in das Gerät hineinzu sehen. Wenn Sie dies tun, können Sie sich einer lebensgefährlichen Laserstrahlung aussetzen. Der Einsatz optischer Geräte mit dieser Laserausrüstung erhöht das Risiko einer Sehschädigung.

### **N.B.**

Dal controllo di questo apparecchio risulta che esso risponde ai valori limite per apparecchi digitali della classe A conf. parte 15 delle direttive sulle telecomunicazioni dell'Autorità federale statunitense. Questi valori limite sono stati fissati per garantire una protezione adeguata contro gli effetti nocivi se questo apparecchio viene usato all'intero di un negozio. L'apparecchio genera, utilizza e può emettere energia ad alta frequenza e, se non viene installato ed utilizzato conformemente alle indicazioni fornite nel Manuale utente, può provocare disturbi al servizio radiofonico. L'uso di questo apparecchio in zone residenziali causa molto probabilmente dei disturbi. In questo caso l'utente è obbligato ad eliminare questi disturbi a sue spese. Qualsiasi sostituzione o modifica non autorizzata all'apparecchio potrebbe rendere invalida l'autorizzazione dell'utente all'uso dell'apparecchio.

### **N.B.**

Questo apparecchio digitale non supera I valori limite per l'emissione di radiorumori da parte di apparecchi digitali della classe A conformemente alle direttive per radiodisturbi del Ministero canadese per l'Industria.

### **Attenzione**

L'utilizzo di sistemi di controllo, di regolazioni o di procedimenti diversi da quelli decritti nel presente Manuale può provocare dei raggi laser pericolosi per la vita. Il cliente non deve assolutamente tentare di riparare egli stesso lo scanner laser. Non guardate mai nel raggio laser, anche se credete che lo scanner non sia attivo. Non aprite mai lo scanner per guardare dentro l'apparecchio. Se tuttavia lo fate, potete esporVi a dei raggi laser pericolosi per la vita. L'uso di apparecchi ottici con questo equipaggiamento laser aumenta il rischio di danni alla vista.

## Appendix F

---

### Patents

#### “Patent Information

This METROLOGIC product may be covered by one or more of the following U.S. Patents:

U.S. Patent No. 4,360,798; 4,369,361; 4,387,297; 4,460,120; 4,496,831; 4,593,186; 4,607,156; 4,673,805; 4,736,095; 4,758,717; 4,816,660; 4,845,350; 4,896,026; 4,923,281; 4,933,538; 4,992,717; 5,015,833; 5,017,765; 5,059,779; 5,117,098; 5,124,539; 5,130,520; 5,132,525; 5,140,144; 5,149,950; 5,180,904; 5,200,599; 5,229,591; 5,247,162; 5,250,790; 5,250,791; 5,250,792; 5,262,628; 5,280,162; 5,280,164; 5,304,788; 5,321,246; 5,324,924; 5,396,053; 5,396,055; 5,408,081; 5,410,139; 5,436,440; 5,449,891; 5,468,949; 5,479,000; 5,532,469; 5,545,889

No license right or sublicense is granted, either expressly or by implication, estoppel, or otherwise, under any METROLOGIC or third party intellectual property rights (whether or not such third party rights are licensed to METROLOGIC), including any third party patent listed above, except for an implied license only for the normal intended use of the specific equipment, circuits, and devices represented by or contained in the METROLOGIC products that are physically transferred to the user, and only to the extent of METROLOGIC’s license rights and subject to any conditions, covenants and restrictions therein.”

**IMPORTANT!**  
KEEP THIS CARD WITH THE SCANNER

Scan for Softer Volume



SCAN FOR SOFTER VOLUME. SAVE THIS CARD.  
LEES CODE VOOR STILLER VOLUME. KAART BIJHOUDEN.  
DIESER CODE VERRINGERT DIE LAUTSTÄRKE. BITTE KARATE AUFHEBEN.  
LIRE CE CODE POUR BAISSER LE VOLUME. CONSERVER CETTE CARTE.  
LEER CONDIGO PARA BAJAR VOLUME. GUARDAR ESTA CARTA.  
QUESTO CODICE DIMINUISCE IL VOLUME. CONSERVATE LA CARTA.  
LER O CÓDIGO PARA VOLUME MAIS BAIXO. GUARDAR ESTE CARTÃO.  
ПРОСКАНИРУЙТЕ ЭТОТ КОД ДЛЯ ЦОНИЖЕНИЯ  
ГРМКОСТИ. СОХРАНИТЕ ЭТУ КАРТОЧКУ.

扫描低音 保留卡片

音量減少にはこのカードをスキャンして  
下さい。

### Metrologic<sup>®</sup>

#### USA Corporate Headquarters

Metrologic Instruments, Inc.  
Blackwood, NJ 08012  
Customer Service: 1-800-ID-METRO  
Tel: 609-228-8100  
Fax: 609-228-6673

#### South America

Metrologic Instruments  
CEP 04571-090, São Paulo-SP, Brasil  
Outside Brazil:  
Tel: 55-11-5505-6568  
Fax: 55-11-5505-1681  
In Brazil:  
Tel: 55-11-5505-2396  
Fax: 55-11-5507-2301

#### Europe

Metrologic Instruments GmbH  
Munich, Germany  
Tel: 49-89-89018-0  
Fax: 49-89-89019-200

#### ASIA

Metrologic Asia (PTE) Ltd.  
Singapore 417818  
Tel: 65-842-7155  
Fax: 65-842-7166



# IMPORTANT!

## KEEP THIS CARD WITH THE SCANNER

Scan for Louder Volume



SCAN FOR LOUDER VOLUME. SAVE THIS CARD.  
LEES CODE VOOR LUIDER VOLUME. KAART BIJHOUDEN.  
DIESER CODE ERHÖHT DIE LAUTSTÄRKE. BITTE KARTE AUFHEBEN.  
LIRE CE CODE POUR AUGMENTER LE VOLUME. CONSERVER CETTE CARTE.  
LEER CODIGO PARA AUMENTAR VOLUME. GUARDAR ESTA CARTA.  
QUESTO CODICE AUMENTA IL VOLUME. CONSERVATE LA CARTA.  
LER O CÓDIGO PARA VOLUME MAIS ALTO. GUARDAR ESTE CARTÃO.  
ПРОСКАНИРУЙТЕ ЭТОТ КОД ДЛЯ ЦОВЪЩЕНИЯ  
ГРМОСТИ. СОХРАНИТЕ ЭТУ КАРТОЧКУ.

扫描高音 保留卡片

音量増大にはこのカードをスキヤンして  
下さい。

### Metrologic

#### USA Corporate Headquarters

Metrologic Instruments, Inc.  
Blackwood, NJ 08012  
Customer Service: 1-800-ID-METRO  
Tel: 609-228-8100  
Fax: 609-228-6673

#### South America

Metrologic Instruments  
CEP 04571-090, São Paulo-SP, Brasil  
Outside Brazil:  
Tel: 55-11-5505-6568  
Fax: 55-11-5505-1681  
In Brazil:  
Tel: 55-11-5505-2396  
Fax: 55-11-5507-2301

#### Europe

Metrologic Instruments GmbH  
Munich, Germany  
Tel: 49-89-89018-0  
Fax: 49-89-89019-200

#### ASIA

Metrologic Asia (PTE) Ltd.  
Singapore 417818  
Tel: 65-842-7155  
Fax: 65-842-7166

# Index

---

## A

- AC input/outlet 3, 10, 34
- Adaptor 7, 10
  - cable 6, 9
  - kit 46
- Application 34
- Application and protocols 33
- Asia ii
- Assignments
  - pin 36-41
- Attaching stand 12, 13

## B

- Bar codes 1, 4, 11, 19
- Beep 3, 4, 7, 14, 15, 18
- Beeper operation 35
- Base 12

## C

- Cable
  - adaptor 6, 9
  - cloning 5
  - communication 2, 3, 9, 10, 14, 42-46
  - head 3, 10, 14, 33, 42-46
- CDRH class IIa 20, 34
- Class 1 34
- Clean 33, 35
- Communication protocol 33
- Communications buffer 7
- Communications bus 6
- Compliance 3, 10
- Configuration 4, 6, 8, 9, 46
- Contrast 35
- Copyright ii
- Current 34
- Customer Service ii, 47

## D

- DC transformer 34

- Decode capability 35
- Default settings 36-41
- Depth of field 1, 23, 24, 27-32, 35
- Dimensions 34
- Disclaimer 48

## E

- Electrical 34
- Email ii
- Environmental 35
- ESD 35
- Europe ii
- External Power supply 6

## F

- Faulty equipment 47
- Fax ii
- Functions 36-46

## G

- Germany (GmbH) ii, 47
- Good read 14, 35
- Green LED 3, 11, 14, 15, 21

## H

- Headquarters ii
- Host 3, 4, 34, 42-45
- Humidity 35

## I

- Indicators
  - LED 1, 3, 11, 14, 15-18, 21, 35
  - Visual 15-18
- Interfaces 35
- Installation
  - Scanner 9, 10
  - Stand 2, 12, 13

Internet	ii
Introduction	1
<b>K</b>	
Keyboard Wedge	9, 33, 35, 46
<b>L</b>	
Labels	20
LASERKLASSE 1	20
LEDs	1, 3, 11, 14, 15-18, 21, 35
Light levels	35
Light pen emulation	9, 33, 35, 42, 46
Light source	34
Limited warranty	47
List	2
Locations	ii
<b>M</b>	
Maintenance	33, 35
Mechanical	34
Model number	20, 33
<b>N</b>	
Notices	49, 50
<b>O</b>	
OCIA	33, 35, 42, 45
Operating current	34
Operating temperature	35
Operation	4, 21
Operational	35
Orientation	34
Symbol	22
Output format	6
Output window	14, 33
<b>P</b>	
Parts	14
Patents	51
PC	1, 9, 10, 11, 35, 46
Pin assignments	42-46
Port(s)	6-9
Power consumption	34
Power supply	2, 6, 34
Print contrast	35
Programming guide	1, 2, 4, 9, 19, 21, 46
Protocols	33
<b>R</b>	
Red LED	14, 15
Repair	47
Rights	
property	51
warranty	47
RMA	47
Roll, pitch, yaw	22, 35
RS-232	4, 9, 33, 35, 42, 45, 46
RS-422	33, 35, 44
RS-485	33, 45
<b>S</b>	
Scan field(s)	15, 27, 30, 35
Scan lines	35
Scan pattern	27, 3., 35
Scanner connections	3, 4
ScanSet	1, 4, 7, 15-19, 21, 46
ScanSelect manual	1, 2, 4, 7, 9, 19, 21, 46
Scan speed	1, 35
Service	47
Shipping carton	2
Socket-outlet	3, 10
South America	ii
Specifications	34, 35
Stand	2, 12
Storage temperature	35
System interfaces	35
<b>T</b>	
Temperature	35
Tones	35
Top cover	34
Transformer	3, 5, 10, 11, 15, 34, 42-46

## **U**

UL/CSA/TUV 34

USA corporate headquarters

ii

## **V**

Ventilation 35

Version identifiers 33

Voltage 3, 10, 34

Volume control card 52, 53

## **W**

Warranty 47

Watt(s) 1, 34

Weight 34

Window 1, 24, 27, 30, 33-35